

09/28/09

TIP PROJECT: R-3329 / R-2559

CONTRACT: C202587

R:\Hydraulics\Permit Environmental\R-3329\_r\_2559\_rdy\_tsh\_Sec3a-permit.dgn

STATE OF NORTH CAROLINA  
DIVISION OF HIGHWAYS

MECKLENBURG & UNION COUNTY

LOCATION: US 74 BYPASS FROM US 74 JUST EAST OF I-485 NEAR MATTHEWS AND STALLINGS TO US 74 JUST EAST OF WINGATE AND WEST OF MARSHVILLE

TYPE OF WORK: DESIGN-BUILD

WETLAND & STREAM IMPACTS

STATE	STATE PROJECT REFERENCE NO.	SHEET NO.	TOTAL SHEETS
N.C.	R-3329 /R-2559	1	
STATE PROJ. NO.	F.A. PROJ. NO.	DESCRIPTION	
34533.5.TA1			

PERMIT DRAWINGS  
SHEET 177 OF 267

PRELIMINARY PLANS  
DO NOT USE FOR CONSTRUCTION

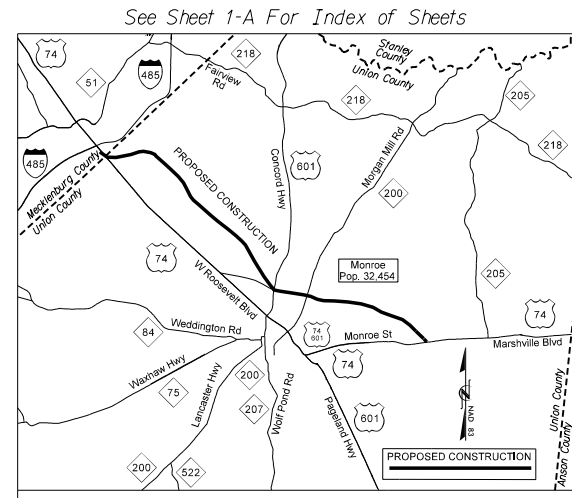

VICINITY MAP

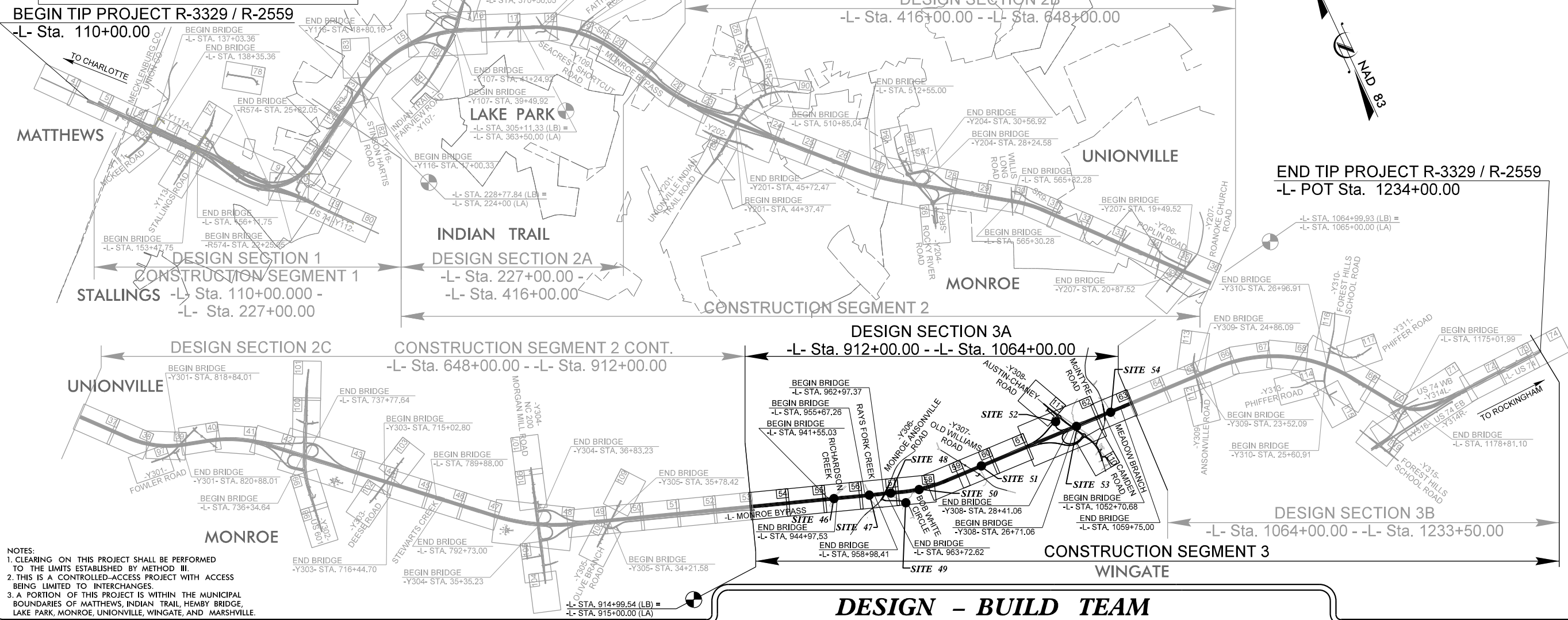

NOTES:  
 1. CLEARING ON THIS PROJECT SHALL BE PERFORMED TO THE LIMITS ESTABLISHED BY METHOD III.  
 2. THIS IS A CONTROLLED-ACCESS PROJECT WITH ACCESS BEING LIMITED TO INTERCHANGES.  
 3. A PORTION OF THIS PROJECT IS WITHIN THE MUNICIPAL BOUNDARIES OF MATTHEWS, INDIAN TRAIL, HEMBY BRIDGE, LAKE PARK, MONROE, UNIONVILLE, WINGATE, AND MARSHVILLE.

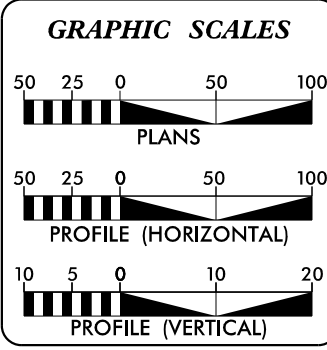

**DESIGN DATA**

ADT 2013 =	64,100
ADT 2035 =	95,600
DHV =	8%
D =	55%
T =	18%*
V =	70 mph

\*TTST 11% DUAL 7%  
FUNCTIONAL CLASS.: FREEWAY

**PROJECT LENGTH**

LENGTH ROADWAY TIP PROJECT R-3329 /R-2559.....	18.1 mi
LENGTH STRUCTURE TIP PROJECT R-3329 /R-2559.....	*1.6 mi
TOTAL LENGTH TIP PROJECT R-3329 /R-2559.....	19.7 mi

\* LENGTH OF STRUCTURES BASED ON WB LANES

**DESIGN - BUILD TEAM**

PLANS PREPARED BY :  
**MULKEY**  
 ENGINEERS & CONSULTANTS  
 PO Box 33127  
 RALEIGH, N.C. 27636  
 (919) 851-1912  
 (919) 851-1918 (FAX)  
 WWW.MULKEYINC.COM  
 NC LICENSE NO. C-1021

2006 STANDARD SPECIFICATIONS

LETTING DATE:  
OCTOBER 28, 2010

Steve A. Drum, P.E.  
PROJECT ENGINEER

Michael A. Holt, P.E.  
PROJECT DESIGN ENGINEER

CONTRACTOR :

CONTRACTOR NAME: M Monroe Bypass Constructors

HYDRAULICS ENGINEER

SIGNATURE: \_\_\_\_\_ P.E.  
ROADWAY DESIGN ENGINEER

SIGNATURE: \_\_\_\_\_ P.E.

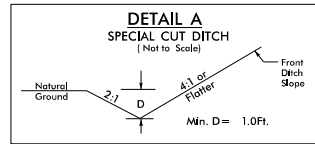

Min. D = 1.0Ft.  
b = 5.0Ft.

-L- STA. 973+75 TO STA. 974+50 LT  
-L- STA. 986+50 TO STA. 987+50 RT  
-L- STA. 1063+50 TO STA. 1064+00 LT  
-Y320- STA. 13+50 TO STA. 14+60 RT  
-DR2- STA. 8+70 TO STA. 9+00 LT

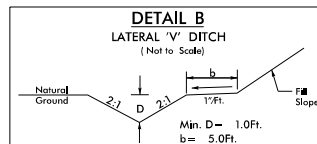

Min. D = 1.0Ft.  
b = 5.0Ft.

-L- STA. 965+00 TO STA. 965+39 LT  
-Y306- STA. 29+50 TO STA. 30+00 RT  
-Y318- STA. 16+00 TO STA. 16+50 LT  
-L- STA. 924+82 TO STA. 924+75 RT  
-L- STA. 977+75 TO STA. 978+20 LT  
-L- STA. 1001+00 TO STA. 1001+75 LT  
-Y308- STA. 30+25 TO STA. 31+75 LT  
-L- STA. 1049+50 TO STA. 1052+00 LT  
-L- STA. 1062+00 TO STA. 1063+73 RT

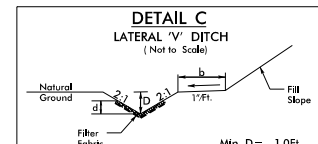

Min. D = 1.0Ft.  
Max. d = 1.0Ft.  
b = 5.0Ft.

Type of Liner = Class B Rip-Rap  
-L- STA. 924+82 TO STA. 925+00 RT  
-L- STA. 928+58 TO STA. 928+88 LT

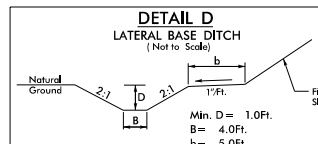

Min. D = 1.0Ft.  
B = 4.0Ft.  
b = 5.0Ft.

-L- STA. 923+41 TO STA. 924+82 RT  
-L- STA. 955+00 TO STA. 955+50 LT  
-L- STA. 959+50 TO STA. 961+50 RT  
-L- STA. 985+00 TO STA. 986+35 LT  
-L- STA. 992+50 TO STA. 993+97 LT  
-L- STA. 1001+75 TO STA. 1002+60 LT  
-VLC- STA. 20+75 TO STA. 22+40 LT  
-L- STA. 1041+65 TO STA. 1043+00 LT

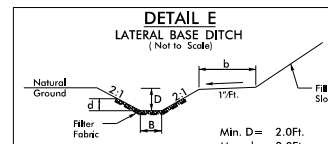

Min. D = 2.0Ft.  
Max. d = 2.0Ft.  
b = 5.0Ft.

Type of Liner = Class B Rip-Rap  
-L- STA. 915+00 TO STA. 916+43 RT  
-L- STA. 916+43 TO STA. 917+00 RT  
-L- STA. 923+40 TO STA. 923+85 LT  
-L- STA. 929+58 TO STA. 930+59 RT  
-L- STA. 937+15 TO STA. 939+50 LT  
-L- STA. 939+50 TO STA. 942+10 LT  
-L- STA. 939+15 TO STA. 941+05 RT  
-L- STA. 946+35 TO STA. 947+20 LT  
-L- STA. 954+70 TO STA. 955+00 LT  
-L- STA. 958+80 TO STA. 962+20 LT  
-Y306- STA. 28+80 RT TO -L- STA. 966+25 RT  
-L- STA. 975+54 TO STA. 977+30 LT  
-L- STA. 976+20 TO STA. 979+00 RT  
-L- STA. 981+44 TO STA. 982+50 LT  
-L- STA. 993+55 TO STA. 998+00 RT  
-L- STA. 993+97 TO STA. 998+50 LT  
-L- STA. 1001+16 TO STA. 1003+00 RT  
-L- STA. 1002+60 TO STA. 1003+15 LT  
-Y308- STA. 21+50 TO STA. 25+35 RT  
-Y308- STA. 20+50 LT TO -VRC- STA. 28+34 RT  
-L- STA. 1039+00 RT TO -Y308- STA. 25+45 LT  
-L- STA. 1041+65 TO STA. 1043+00 LT  
-L- STA. 1059+30 TO STA. 1063+00 LT  
-L- STA. 1060+00 TO STA. 1060+50 RT

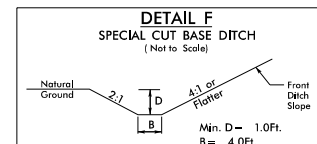

Min. D = 1.0Ft.  
B = 4.0Ft.

-VRB- STA. 17+00 TO STA. 26+30 LT  
-Y308- STA. 35+00 TO STA. 36+50 LT  
-VRB- STA. 18+50 TO STA. 23+50 RT

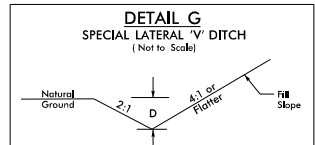

Min. D = 1.0Ft.

DETAIL G NOT USED IN SECTION 3A

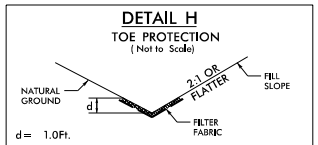

d = 1.0Ft.

Type of Liner = Class B Rip-Rap  
-L- STA. 928+97 TO STA. 929+50 LT  
-L- STA. 964+50 TO STA. 965+00 LT  
-Y308- STA. 31+75 TO STA. 32+50 LT  
-L- STA. 1050+50 TO STA. 1051+50 RT  
-L- STA. 1052+00 TO STA. 1052+68 LT

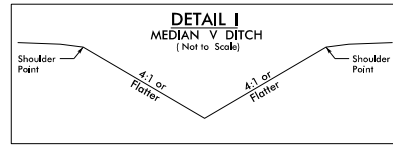

-L- STA. 1020+00 TO STA. 1023+50 CL

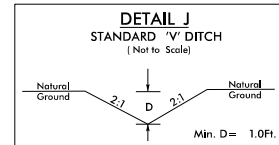

Min. D = 1.0Ft.

-Y318- STA. 23+70 TO STA. 24+00 LT  
L = 35', S = 1.50%  
BEG EL = 455.50, END EL = 456.03  
-Y308- STA. 37+35 LT, L = 35', S = 2.77%  
BEG EL = 549.74, END EL = 548.77  
-Y308- STA. 28+91 RT, L = 55', S = 3.18%  
BEG EL = 520.75, END EL = 519.00  
-Y308- STA. 28+91 RT, L = 110', S = 7.27%  
BEG EL = 519.00, END EL = 511.00

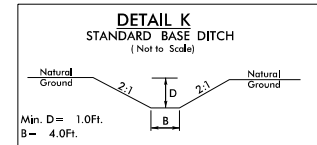

Min. D = 1.0Ft.  
B = 4.0Ft.

-L- STA. 942+10 TO STA. 943+50 LT; L=140', S=4.6%  
BEG EL=456.4, END EL=450.0  
-L- STA. 943+50 TO STA. 944+04 LT; L=54', S=1.9%  
BEG EL=450.0, END EL=449.0  
-L- STA. 955+50 TO STA. 956+82 LT; L=132', S=2.0%  
BEG EL=452.0, END EL=449.36  
-L- STA. 957+13 TO STA. 958+80 LT; L=167', S=2.65%  
BEG EL=449.55, END EL=453.98  
-L- STA. 957+50 TO STA. 958+00 RT; L=50', S=1.00%  
BEG EL=449.50, END EL=450.00  
-L- STA. 958+00 TO STA. 958+50 RT; L=50', S=3.00%  
BEG EL=450.00, END EL=451.50  
-L- STA. 958+50 TO STA. 959+50 RT; L=100', S=0.50%  
BEG EL=451.50, END EL=452.00  
-Y308- STA. 35+75 LT; L=45', S=2.4%  
BEG EL=542.42, END EL=543.50  
-Y319- STA. 23+12 RT; L=45', S=14.00%  
BEG EL=515.0, END EL=508.7  
-Y319- STA. 23+55 RT; L=100', S=0.50%  
BEG EL=508.7, END EL=508.2

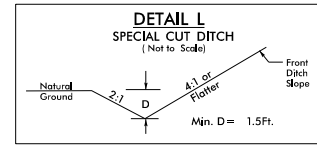

Min. D = 1.5Ft.

DETAIL L NOT USED IN SECTION 3A

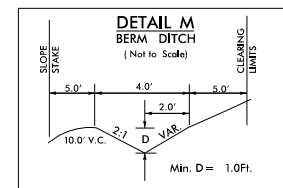

Min. D = 1.0Ft.

-L- STA. 913+25 TO STA. 913+75 LT  
-L- STA. 919+25 TO STA. 921+00 LT  
-L- STA. 1019+00 TO STA. 1020+00 LT  
-VRC- STA. 14+50 TO STA. 15+60 RT  
-VRC- STA. 20+40 TO STA. 21+00 RT

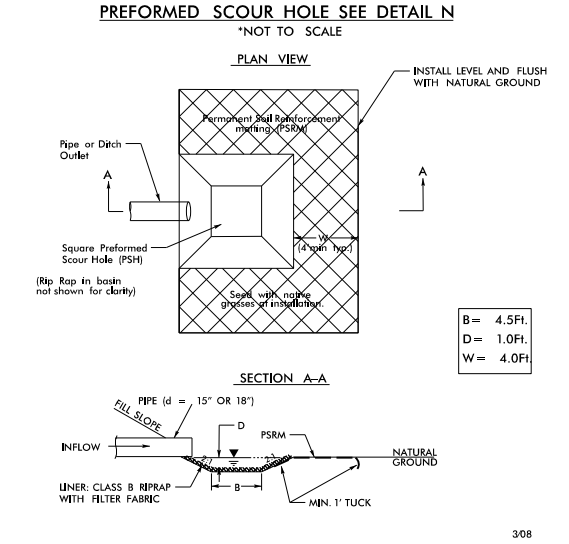

B = 4.5Ft.  
D = 1.0Ft.  
W = 4.0Ft.

-L- STA. 945+65 LT  
-L- STA. 979+00 LT  
-L- STA. 1041+00 LT  
-Y319- STA. 23+60 +/- RT

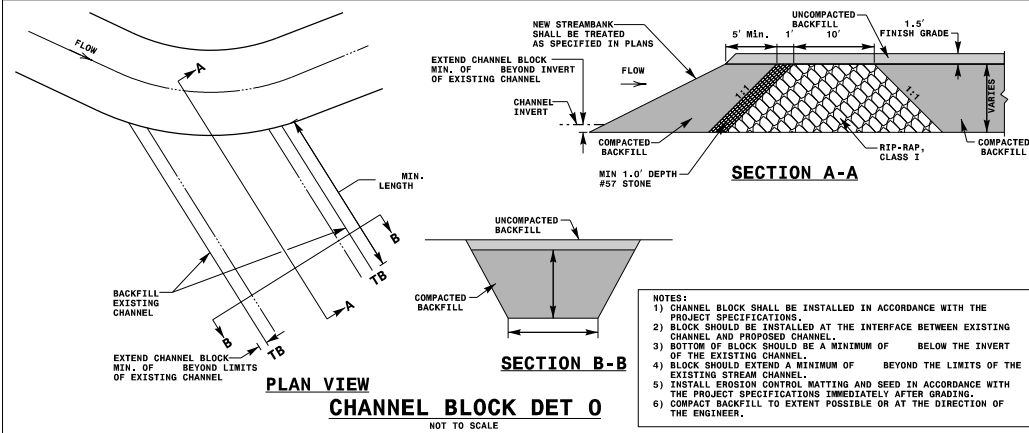

NOTES:  
1) CHANNEL BLOCK SHALL BE INSTALLED IN ACCORDANCE WITH THE PROJECT SPECIFICATIONS.  
2) BLOCK SHOULD BE INSTALLED AT THE INTERFACE BETWEEN EXISTING CHANNEL AND PROPOSED CHANNEL.  
3) BOTTOM OF BLOCK SHOULD BE A MINIMUM OF BELOW THE INVERT OF THE EXISTING CHANNEL.  
4) BLOCK SHOULD EXTEND A MINIMUM OF BEYOND THE LIMITS OF THE EXISTING STREAM CHANNEL.  
5) INSTALL EROSION CONTROL MATTING AND SEED IN ACCORDANCE WITH THE PROJECT SPECIFICATIONS IMMEDIATELY AFTER GRADING.  
6) COMPACT BACKFILL TO EXTENT POSSIBLE OR AT THE DIRECTION OF THE ENGINEER.

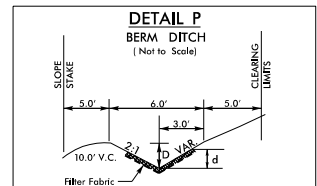

Min. D = 1.5Ft.  
Max. d = 1.5Ft.

Type of Liner = Class B Rip-Rap  
DETAIL P NOT USED IN SECTION 3A

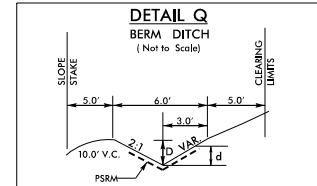

Min. D = 1.5Ft.  
Max. d = 1.5Ft.

Type of Liner = PSRM  
-L- STA. 921+00 TO STA. 921+80 LT  
-L- STA. 930+50 TO STA. 933+80 LT

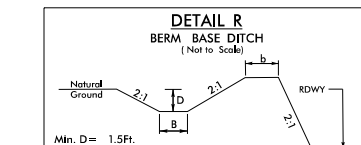

Min. D = 1.5Ft.  
B = 2.0Ft.  
b = 5.0Ft.

-L- STA. 1009+50 TO STA. 1013+00 LT  
-L- STA. 1013+00 TO STA. 1014+00 LT  
-L- STA. 1023+50 TO STA. 1027+00 LT  
-VRB- STA. 16+70 TO STA. 17+00 LT

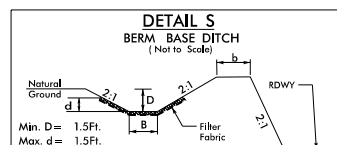

Min. D = 1.5Ft.  
Max. d = 1.5Ft.  
B = 2.0Ft.  
b = 5.0Ft.

Type of Liner = Class B Rip-Rap  
-L- STA. 909+50 TO -L- STA. 913+25 LT

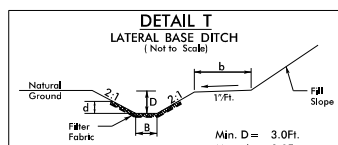

Min. D = 3.0Ft.  
Max. d = 3.0Ft.  
B = 4.0Ft.  
b = 5.0Ft.

Type of Liner = Class B Rip-Rap  
DETAIL T NOT USED IN SECTION 3A

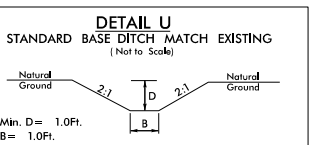

Min. D = 1.0Ft.  
B = 1.0Ft.

-L3A- STA. 997+40 LT, L=60', S=4.8%  
BEG EL=529.89, END EL=527.01

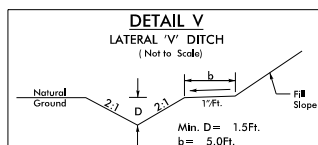

Min. D = 1.5Ft.  
b = 5.0Ft.

DETAIL V NOT USED IN SECTION 3A

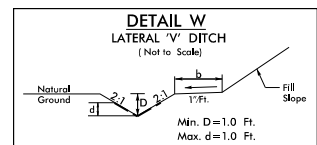

Min. D = 1.0 Ft.  
Max. d = 1.0 Ft.  
b = 5.0 Ft.

Type of Liner = PSRM

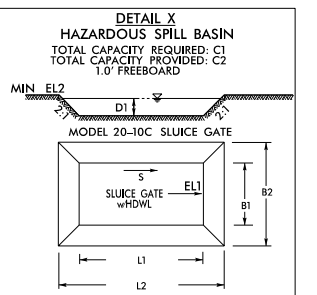

DETAIL X NOT USED IN SECTION 3A

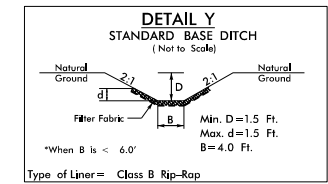

Type of Liner = Class B Rip-Rap  
 -L- STA. 941+05 TO STA. 941+50 RT; L=45', S=10.5%  
 BEG EL=456.7, END EL=452.0  
 -L- STA. 941+50 TO STA. 942+38 RT; L=88', S=4.6%  
 BEG EL=452.0, END EL=448.0  
 -L- STA. 1059+50 TO STA. 1060+00 RT  
 L=50', S=0.50%  
 BEG EL=509.00, END EL=509.25  
 -Y319- STA. 21+35 RT  
 L=52', S=0.40%  
 BEG EL=510.20, END EL=510.00

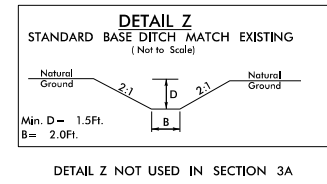

DETAIL Z NOT USED IN SECTION 3A

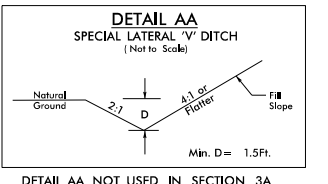

DETAIL AA NOT USED IN SECTION 3A

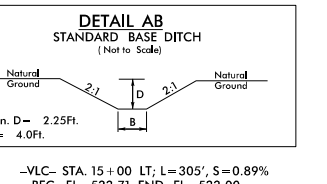

-VLC- STA. 15+00 LT; L=305', S=0.89%  
 BEG EL=522.71, END EL=522.00

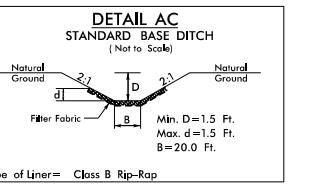

Type of Liner = Class B Rip-Rap  
 -L- STA. 1058+60 TO STA. 1059+30 LT  
 L=70', S=0.20%  
 BEG EL=508.50, END EL=508.58

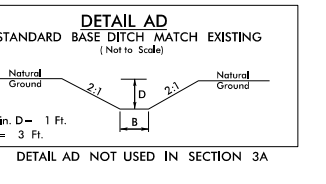

DETAIL AD NOT USED IN SECTION 3A

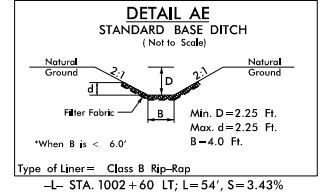

Type of Liner = Class B Rip-Rap  
 -L- STA. 1002+60 LT; L=54', S=3.43%  
 BEG EL=530.35, END EL=528.50  
 -L- STA. 1002+60 LT; L=27', S=1.00%  
 BEG EL=528.50, END EL=528.23  
 -Y308- STA. 30+00 RT; L=214', S=1.55%  
 BEG EL=514.31, END EL=511.00  
 -Y308- STA. 32+85 LT; L=23', S=0.30%  
 BEG EL=518.04, END EL=517.97

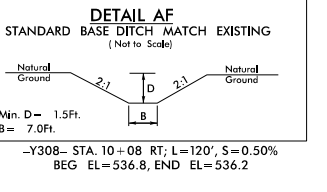

-Y308- STA. 10+08 RT; L=120', S=0.50%  
 BEG EL=536.8, END EL=536.2

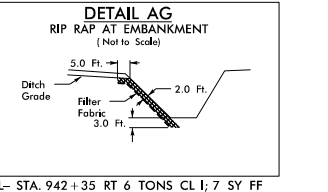

-L- STA. 942+35 RT 6 TONS CL I; 7 SY FF  
 -L- STA. 944+07 LT 5 TONS CL I; 7 SY FF  
 -L- STA. 956+80 LT 6 TONS CL I; 7 SY FF  
 -L- STA. 957+13 LT 7 TONS CL I; 7 SY FF  
 -L- STA. 957+50 RT 18 TONS CL I; 18 SY FF  
 -Y308- STA. 29+51 RT 5 TONS CL I; 7 SY FF  
 -Y308- STA. 28+43 RT 5 TONS CL I; 7 SY FF  
 -Y308- STA. 25+45 LT 10 TONS CL I; 14 SY FF  
 -VRC- STA. 28+34 RT 10 TONS CL I; 14 SY FF

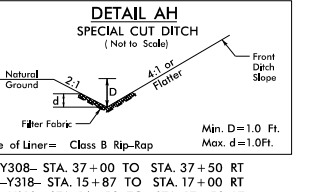

Type of Liner = Class B Rip-Rap  
 -Y308- STA. 37+00 TO STA. 37+50 RT  
 -Y318- STA. 15+87 TO STA. 17+00 RT  
 -Y318- STA. 16+50 TO STA. 17+50 LT

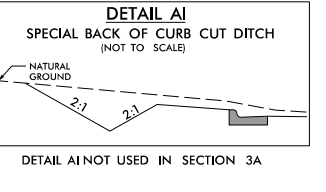

DETAIL AI NOT USED IN SECTION 3A

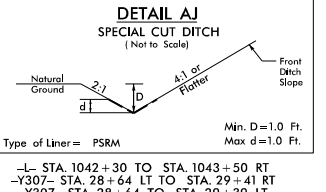

Type of Liner = PSRM  
 -L- STA. 1042+30 TO STA. 1043+50 RT  
 -Y307- STA. 28+64 LT TO STA. 29+41 RT  
 -Y307- STA. 28+64 TO STA. 29+39 LT  
 -Y308- STA. 13+50 TO STA. 14+60 LT  
 -Y308- STA. 14+50 TO STA. 16+49 LT  
 -Y308- STA. 20+50 TO STA. 21+50 RT  
 -Y308- STA. 33+50 TO STA. 35+00 RT  
 -VLC- STA. 18+00 TO STA. 20+35 LT

**DETAIL FALSE SUMP (Not to Scale)**

S = Ditch Slope  
 L = Length of Sump  
 G = Proposed Ditch

Ditch Grade	L	Ditch Grade	L
0.0% To 2.0%	20'	Over 4.0% To 6.0%	40'
Over 2.0% To 4.0%	30'	Over 6.0%	50'

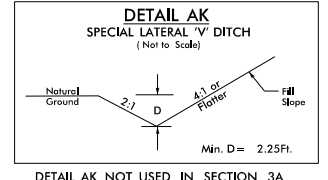

DETAIL AK NOT USED IN SECTION 3A

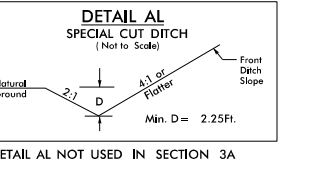

DETAIL AL NOT USED IN SECTION 3A



**DETAIL AN**  
RIP-RAPPED ENERGY DISSIPATOR BASIN

\*NOTE A: IF EXIT VELOCITY OF BASIN IS SPECIFIED, EXTEND BASIN AS REQUIRED TO OBTAIN SUFFICIENT CROSS SECTIONAL AREA AT SECTION A-A SUCH THAT Q DES/(CROSS SECTION AREA AT SEC. A-A) = SPECIFIED VELOCITY.

\*NOTE B: WARP BASIN TO CONFORM TO NATURAL STREAM CHANNEL TOP OF RIP-RAP IN FLOOR OF BASIN SHOULD BE AT SAME ELEVATION OR LOWER THAN NATURAL CHANNEL BOTTOM. AT SEC. A-A, PROVIDE SMOOTH TRANSITION FROM END OF APRON TO NATURAL CHANNEL WIDTH.

**SECTION A-A**  
FILTER FABRIC

**SECTION B-B**  
EXCAVATE TO THIS LINE BACKFILL w/CLASS 1 RIP-RAP

**SECTION C-C**  
EXCAVATE TO THIS LINE BACKFILL w/CLASS 1 RIP-RAP

**SECTION D-D**  
EXCAVATE TO THIS LINE BACKFILL w/CLASS 1 RIP-RAP

NOTE: W<sub>0</sub> = DIAMETER OF PIPE, WIDTH OF BOX OR SPAN OF PIPE-ARCH CULVERTS

DIM.	1	2	3	4	5	6	7	8
A								
B								
C								
D								
E								
F								
G								
H								

\*ALL DIMENSIONS APPROXIMATE IN FEET

505

CORRESPONDS TO -L- 975+83 9'X7' RCBC

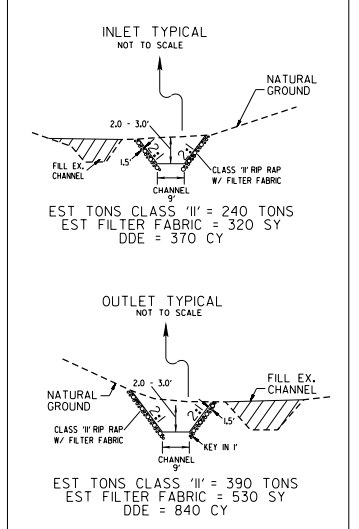

CORRESPONDS TO -L- 1041+25 2@10'X6' RCBC

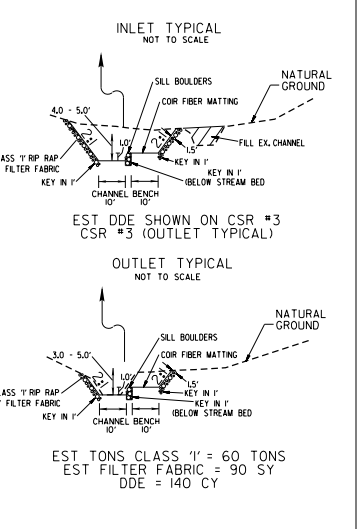

CORRESPONDS TO -Y318- 15+85 9'X7' RCBC

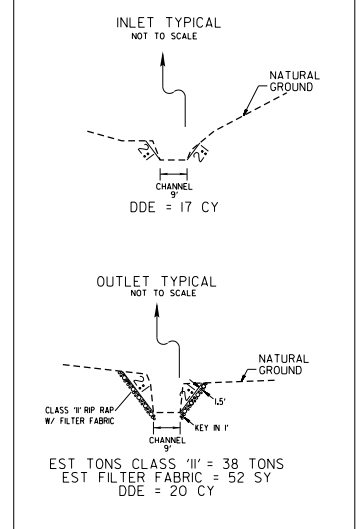

CORRESPONDS TO -VRC- 28+46 2@10'X6' RCBC

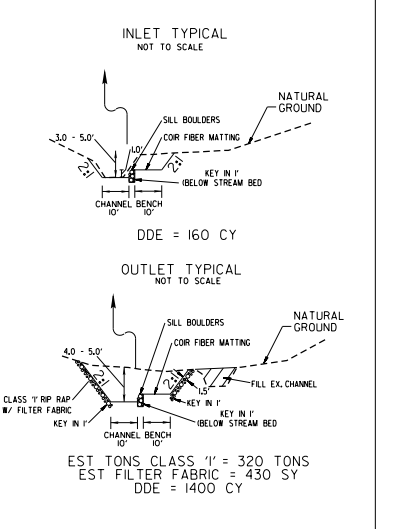

8/17/99

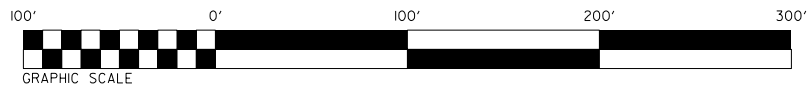

DENOTES IMPACTS IN SURFACE WATER

PROJECT REFERENCE NO. R-3329 / R-2559	SHEET NO. 56
RW SHEET NO.	
ROADWAY DESIGN ENGINEER	HYDRAULICS ENGINEER
<b>INCOMPLETE PLANS</b> DO NOT USE FOR A/W ACQUISITION <b>PRELIMINARY PLANS</b> DO NOT USE FOR CONSTRUCTION	

PERMIT DRAWINGS  
SHEET 180 OF 267



# SITE 46

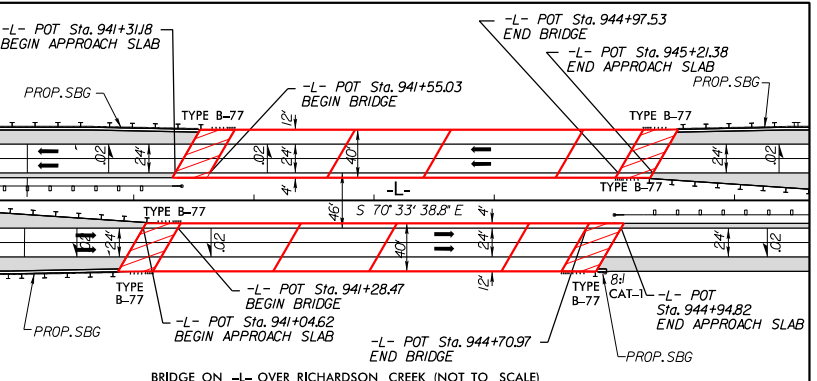
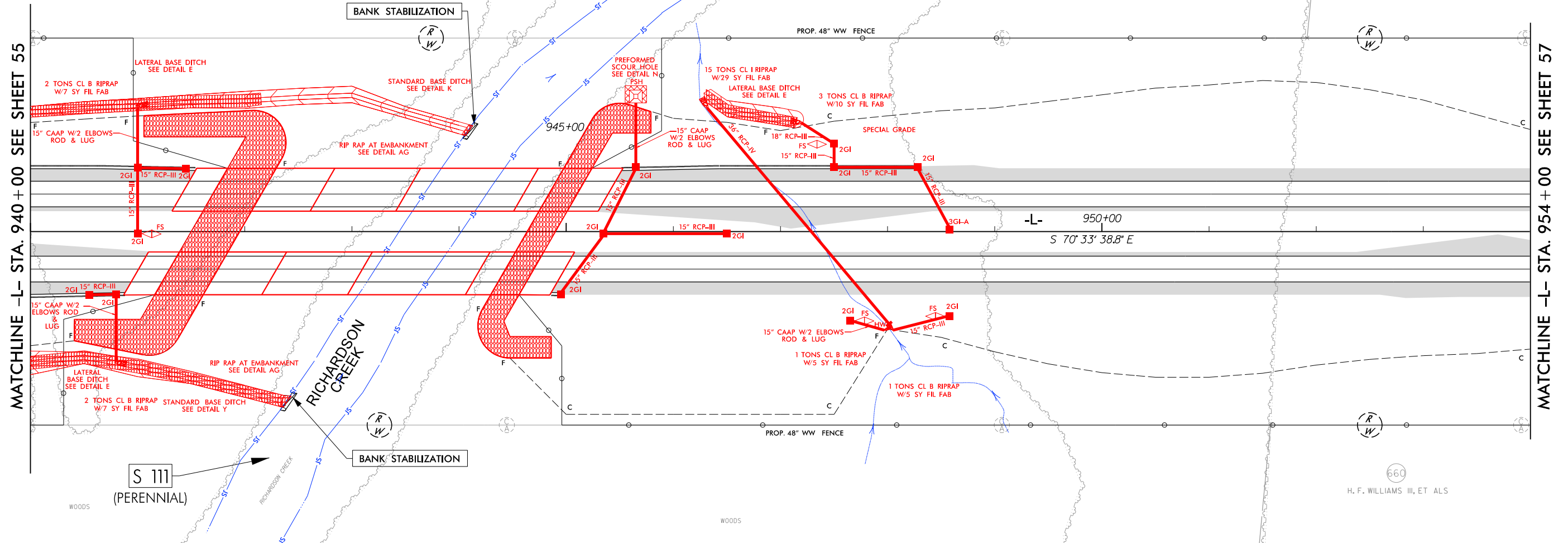

FOR -L- PROFILE SEE SHT.150

PLANS PREPARED BY :

**MULKEY**  
ENGINEERS & CONSULTANTS

PO BOX 33127  
RALEIGH, N.C. 27636  
(919) 851-1912  
(919) 851-1918 (FAX)  
WWW.MULKEYINC.COM

FOR  
THE NORTH CAROLINA  
TURNPIKE AUTHORITY

R:\Hydraulics\Permit Environmental\R3329\_R2559\_hyd\_perm\_PSH\_056.dgn

8/17/99

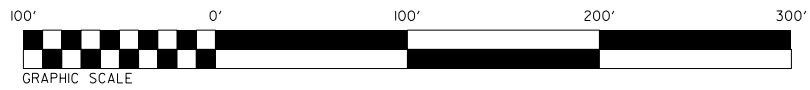

DENOTES IMPACTS IN SURFACE WATER

PROJECT REFERENCE NO. R-3329 / R-2559	SHEET NO. 56
RW SHEET NO.	
ROADWAY DESIGN ENGINEER	HYDRAULICS ENGINEER
<b>INCOMPLETE PLANS</b> DO NOT USE FOR A/W ACQUISITION <b>PRELIMINARY PLANS</b> DO NOT USE FOR CONSTRUCTION	

PERMIT DRAWINGS  
SHEET 181 OF 267

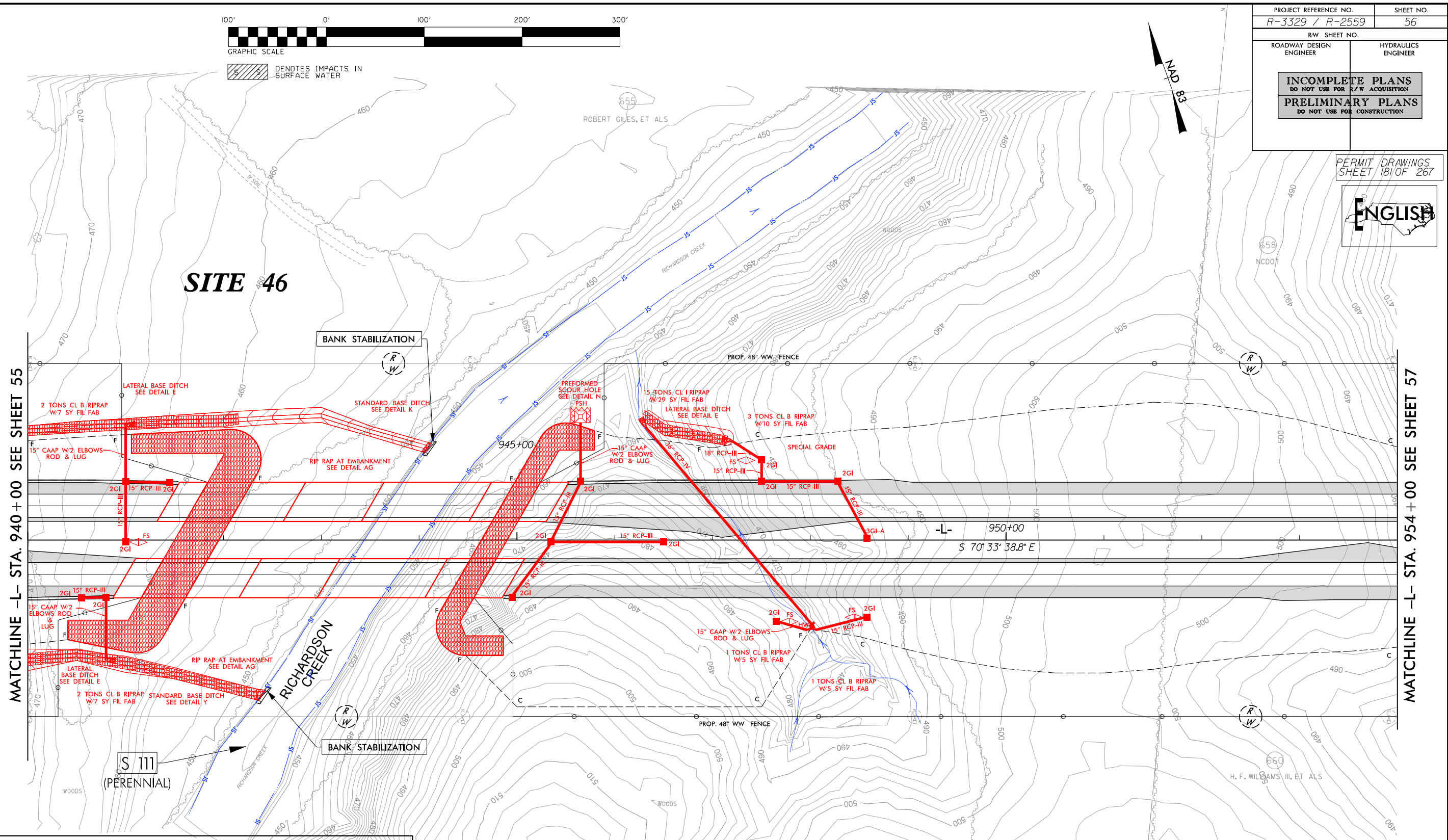

MATCHLINE -L- STA. 940+00 SEE SHEET 55

MATCHLINE -L- STA. 954+00 SEE SHEET 57

R:\Hydraulics\Permit Environmental\R3329\_R2559\_hyd.prm\_PSH\_056\_con.dgn

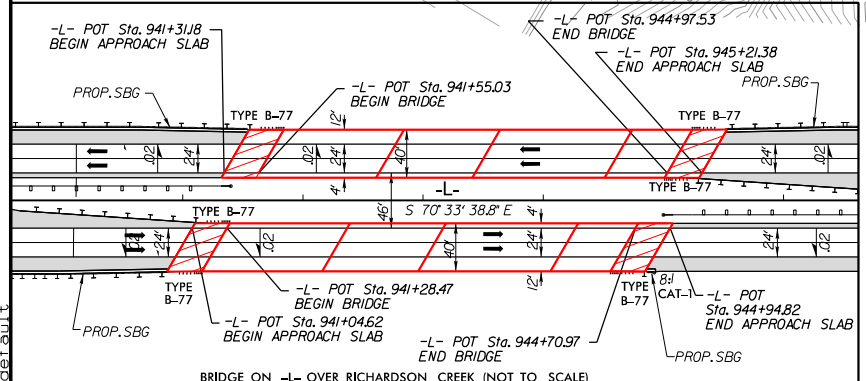

FOR -L- PROFILE SEE SHT.150

PLANS PREPARED BY :

**MULKEY**  
ENGINEERS & CONSULTANTS

PO Box 33127  
RALEIGH, N.C. 27636  
(919) 851-1912  
(919) 851-1918 (FAX)  
WWW.MULKEYINC.COM

FOR  
THE NORTH CAROLINA  
TURNPIKE AUTHORITY

657  
ROBERT GILES, ET ALS

8/17/99

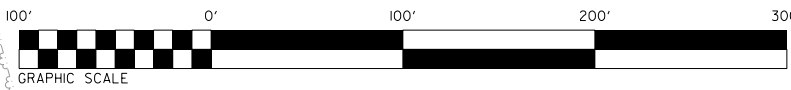
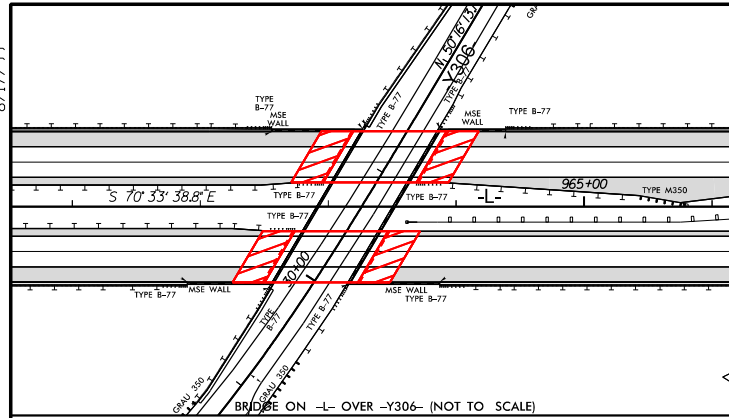

- DENOTES IMPACTS IN SURFACE WATER
- DENOTES FILL IN WETLAND
- DENOTES TEMPORARY FILL IN WETLAND
- DENOTES MECHANIZED CLEARING

661  
H. F. WILLIAMS III, ET ALS

PERMIT DRAWINGS  
SHEET 183 OF 267



PROJECT REFERENCE NO. R-3329 / R-2559	SHEET NO. 57
RW SHEET NO.	
ROADWAY DESIGN ENGINEER	HYDRAULICS ENGINEER
<b>INCOMPLETE PLANS</b> DO NOT USE FOR A/W ACQUISITION <b>PRELIMINARY PLANS</b> DO NOT USE FOR CONSTRUCTION	

PLANS PREPARED BY :

**MULKEY**  
ENGINEERS & CONSULTANTS  
PO BOX 33127  
RALEIGH, N.C. 27636  
(919) 851-1912  
(919) 851-1918 (FAX)  
WWW.MULKEYINC.COM

FOR  
THE NORTH CAROLINA  
TURNPIKE AUTHORITY

MATCHLINE -L- STA. 954+00 SEE SHEET 56

MATCHLINE -L- STA. 968+00 SEE SHEET 58

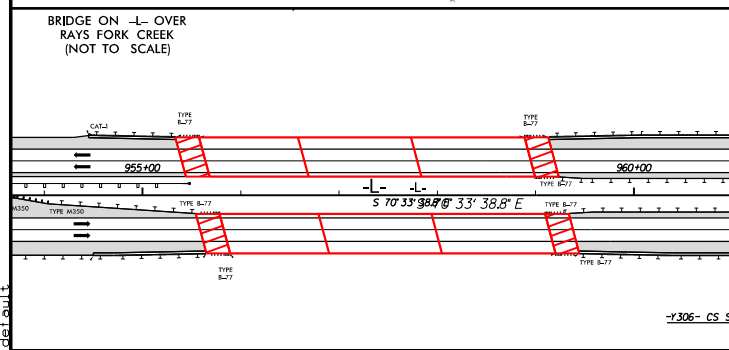
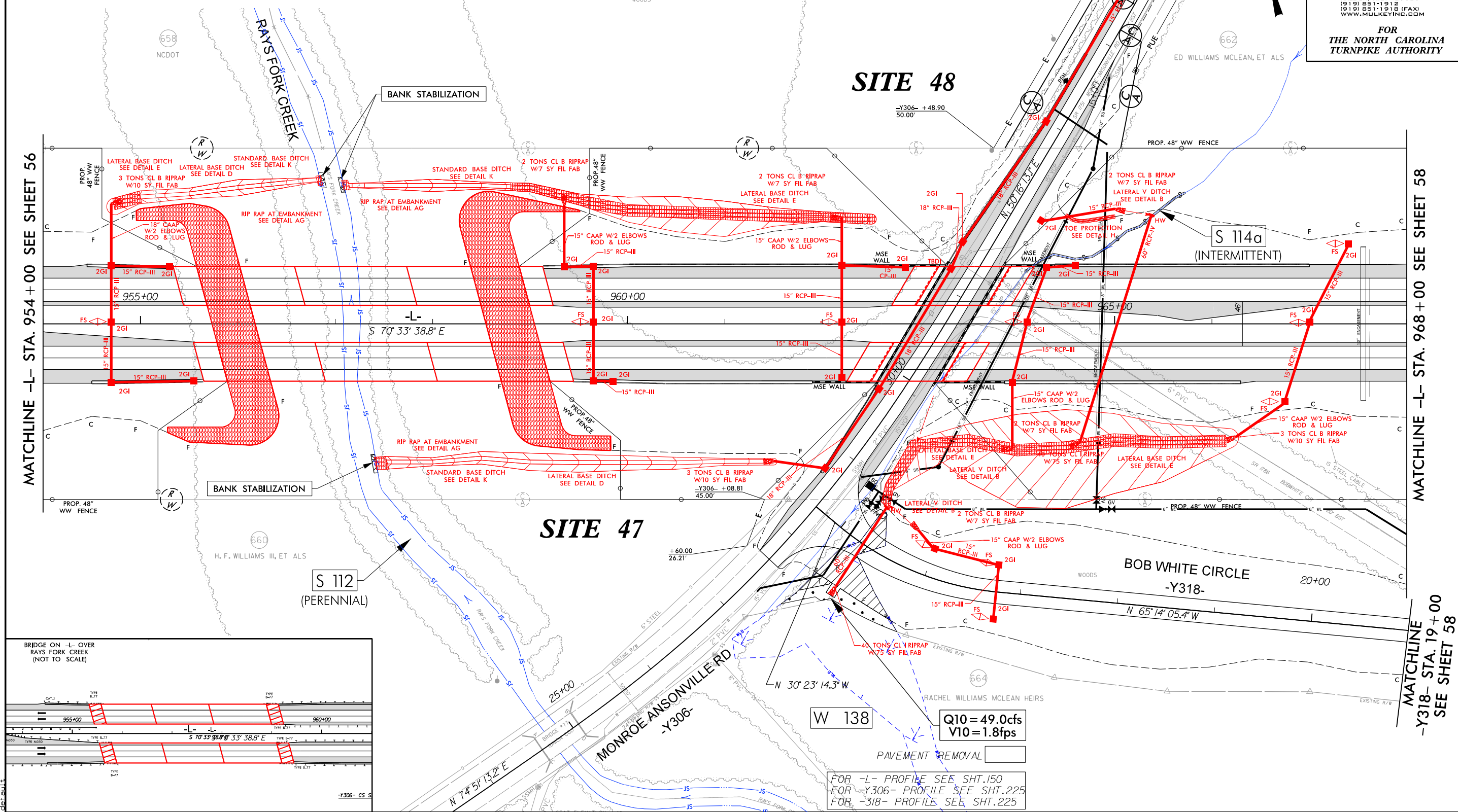

MATCHLINE -Y318- STA. 19+00 SEE SHEET 58

R:\22\2014\Permt Environmental\3329\_R2559\_hyd.prm\_PSH\_057.dgn

8/17/99

PROJECT REFERENCE NO. R-3329 / R-2559	SHEET NO. 57
RW SHEET NO.	
ROADWAY DESIGN ENGINEER	HYDRAULICS ENGINEER
<b>INCOMPLETE PLANS</b> DO NOT USE FOR A/W ACQUISITION <b>PRELIMINARY PLANS</b> DO NOT USE FOR CONSTRUCTION	

PLANS PREPARED BY :

**MULKEY**  
ENGINEERS & CONSULTANTS

PO BOX 33127  
RALEIGH, N.C. 27636  
(919) 851-1912  
(919) 851-1918 (FAX)  
WWW.MULKEYINC.COM

FOR  
THE NORTH CAROLINA  
TURNPIKE AUTHORITY

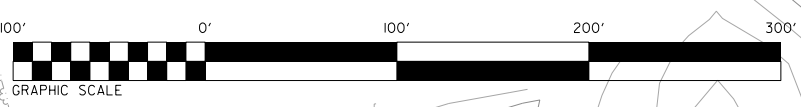

PERMIT DRAWINGS  
SHEET 184 OF 267

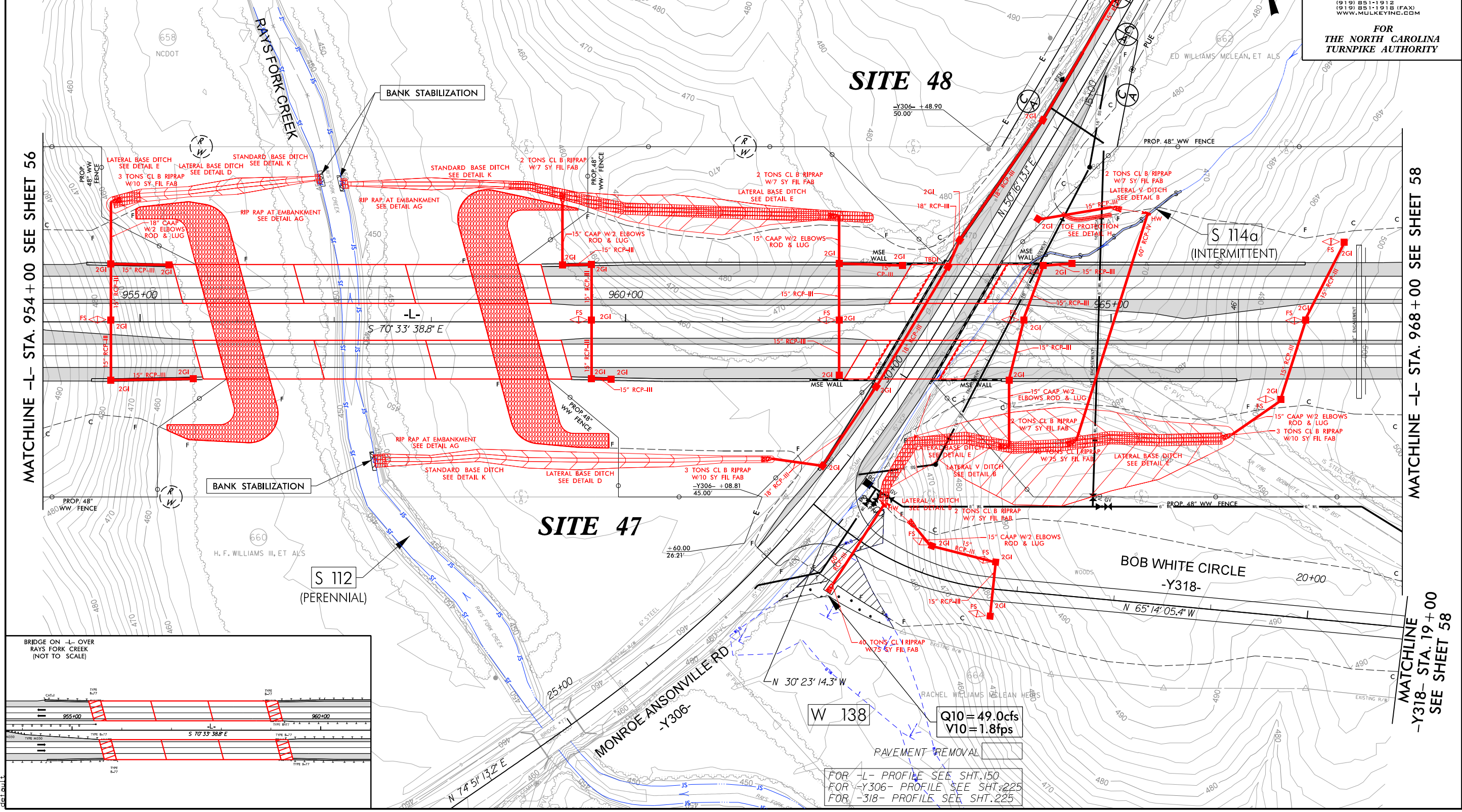
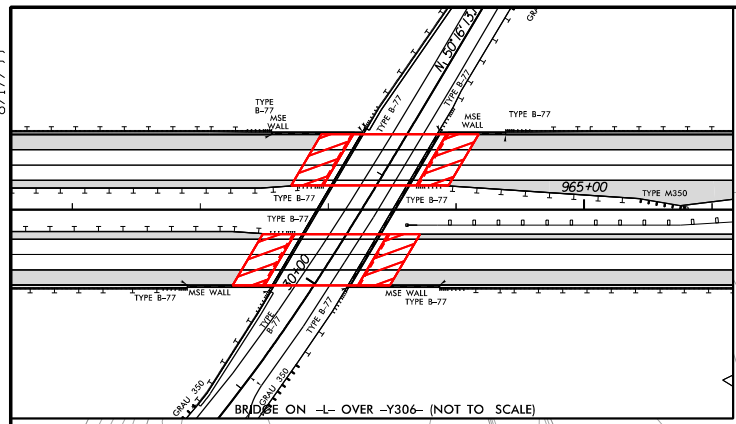

MATCHLINE -L- STA. 954+00 SEE SHEET 56

MATCHLINE -L- STA. 968+00 SEE SHEET 58

MATCHLINE -Y318- STA. 19+00 SEE SHEET 58

R:\22\2014\Permt Environmental\3329\_R2559\_hyd.prm\_PSH\_057\_con.dgn

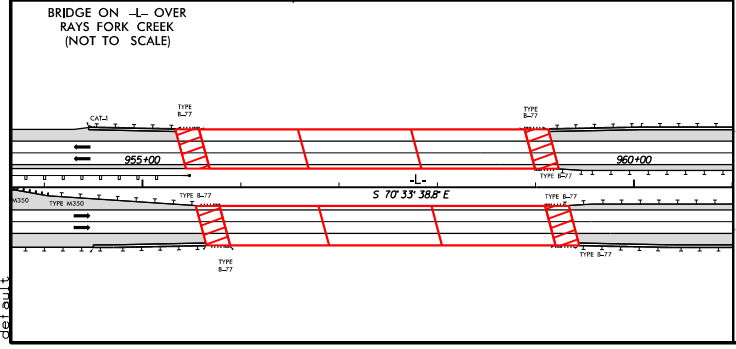

FOR -L- PROFILE SEE SHT.150  
FOR -Y306- PROFILE SEE SHT.225  
FOR -318- PROFILE SEE SHT.225

Q10=49.0cfs  
V10=1.8fps

PAVEMENT REMOVAL

8/17/99  
R:\Hydraulics\Permt Environmental\3329\_R2559\_hyd\_perm\_PSH\_058.dgn

PROJECT REFERENCE NO. R-3329 / R-2559	SHEET NO. 58
RW SHEET NO.	
ROADWAY DESIGN ENGINEER	HYDRAULICS ENGINEER
<b>INCOMPLETE PLANS</b> DO NOT USE FOR A/W ACQUISITION	
<b>PRELIMINARY PLANS</b> DO NOT USE FOR CONSTRUCTION	

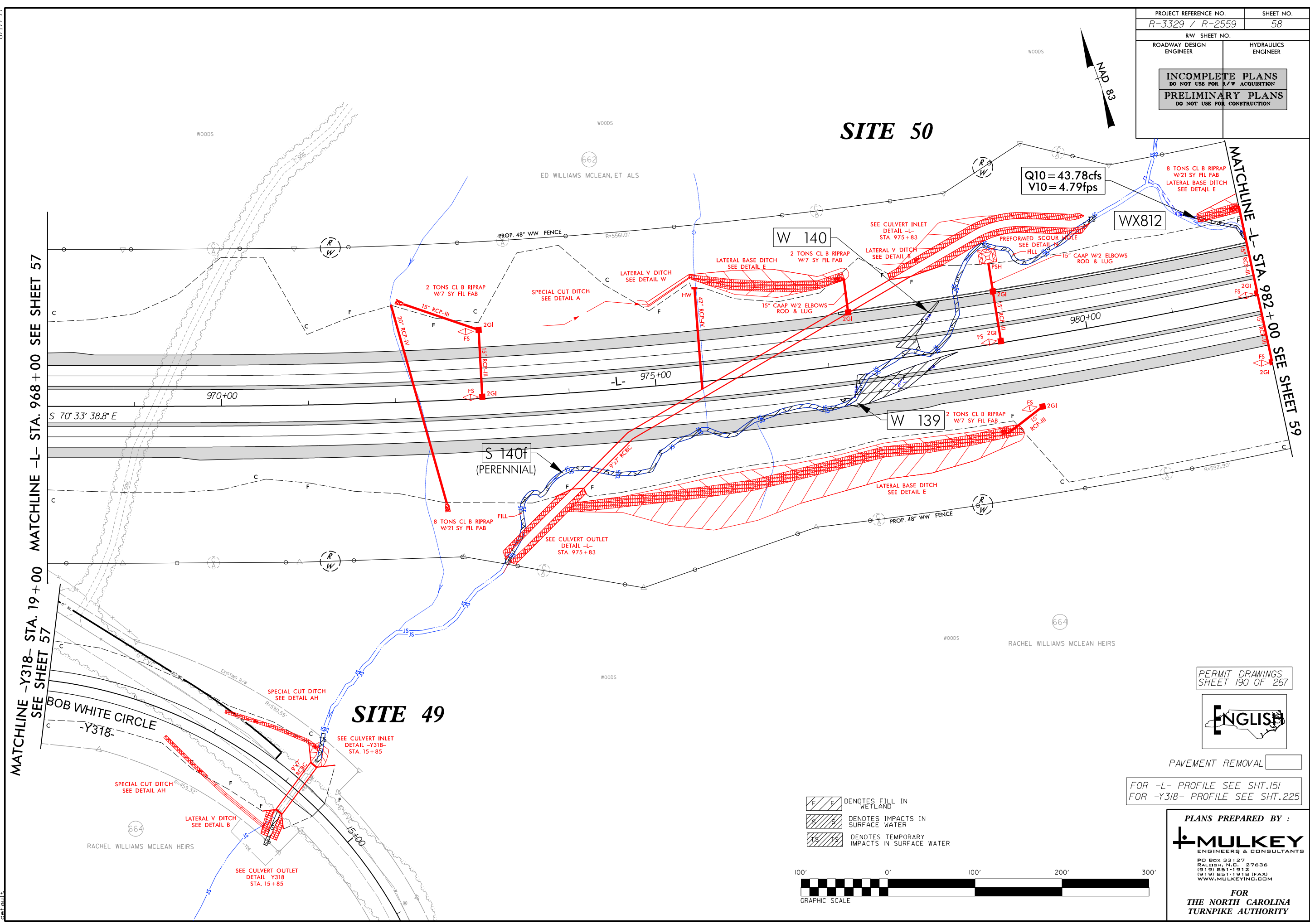

# SITE 50

# SITE 49

MATCHLINE -L- STA. 968+00 SEE SHEET 57  
MATCHLINE -Y318- STA. 19+00 SEE SHEET 57

MATCHLINE -L- STA. 982+00 SEE SHEET 59

Q10 = 43.78cfs  
V10 = 4.79fps

- DENOTES FILL IN WETLAND
- DENOTES IMPACTS IN SURFACE WATER
- DENOTES TEMPORARY IMPACTS IN SURFACE WATER

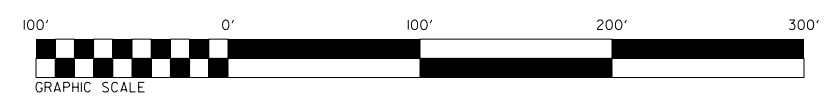

PERMIT DRAWINGS  
SHEET 190 OF 267



PAVEMENT REMOVAL

FOR -L- PROFILE SEE SHT.151  
FOR -Y318- PROFILE SEE SHT.225

PLANS PREPARED BY :

**MULKEY**  
ENGINEERS & CONSULTANTS

PO BOX 33127  
RALEIGH, N.C. 27636  
(919) 851-1912  
(919) 851-1918 (FAX)  
WWW.MULKEYINC.COM

FOR  
THE NORTH CAROLINA  
TURNPIKE AUTHORITY



PROJECT REFERENCE NO. R-3329 / R-2559	SHEET NO. 58
RW SHEET NO.	
ROADWAY DESIGN ENGINEER	HYDRAULICS ENGINEER
<b>INCOMPLETE PLANS</b> DO NOT USE FOR A/W ACQUISITION <b>PRELIMINARY PLANS</b> DO NOT USE FOR CONSTRUCTION	

8/17/99  
 R:\Hydraulics\Permt Environmental\R3329\_R2559\_hyd\_perm\_PSH\_058\_con.dgn  
 8/24/2014

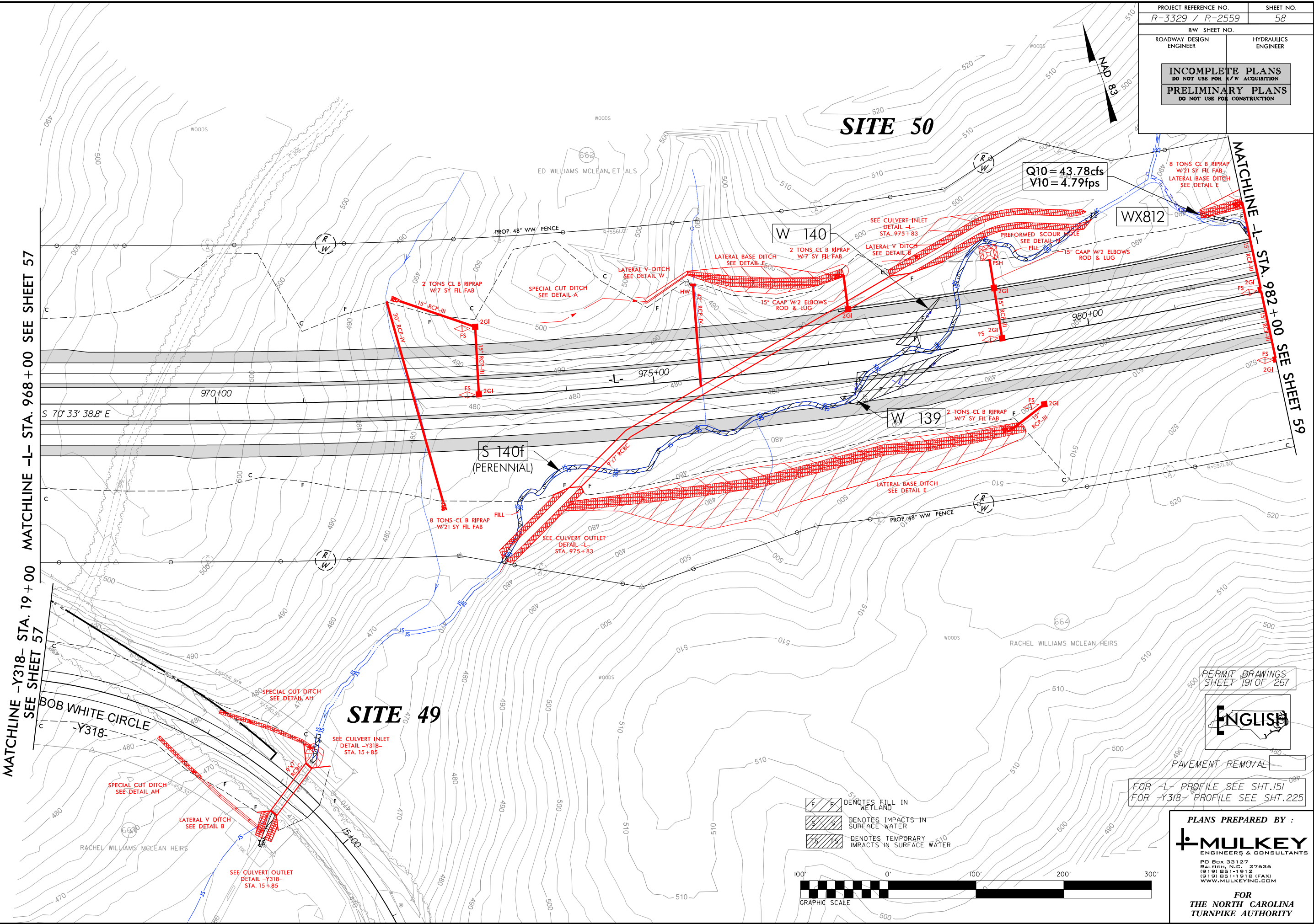

$Q_{10} = 43.78\text{cfs}$   
 $V_{10} = 4.79\text{fps}$

- DENOTES FILL IN WETLAND
- DENOTES IMPACTS IN SURFACE WATER
- DENOTES TEMPORARY IMPACTS IN SURFACE WATER

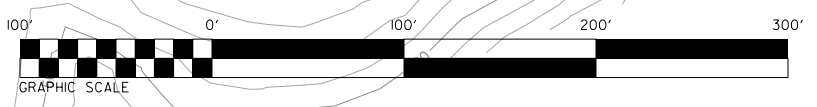

PERMIT DRAWINGS  
SHEET 191 OF 267



FOR -L- PROFILE SEE SHT.151  
 FOR -Y318- PROFILE SEE SHT.225

**PLANS PREPARED BY :**  
**MULKEY**  
 ENGINEERS & CONSULTANTS  
 PO Box 33127  
 RALEIGH, N.C. 27636  
 (919) 851-1912  
 (919) 851-1918 (FAX)  
 WWW.MULKEYINC.COM  
 FOR  
 THE NORTH CAROLINA  
 TURNPIKE AUTHORITY

8/17/99

PROJECT REFERENCE NO. R-3329 / R-2559		SHEET NO. 59	
RW SHEET NO.			
ROADWAY DESIGN ENGINEER		HYDRAULICS ENGINEER	
<b>INCOMPLETE PLANS</b> DO NOT USE FOR A/W ACQUISITION <b>PRELIMINARY PLANS</b> DO NOT USE FOR CONSTRUCTION			

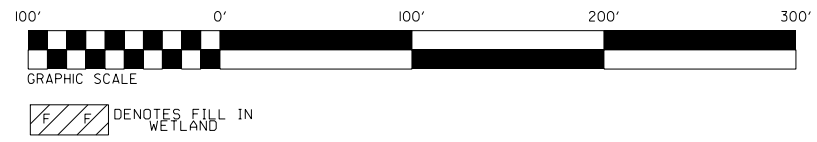

# SITE 50

PERMIT DRAWINGS  
SHEET 192 OF 267

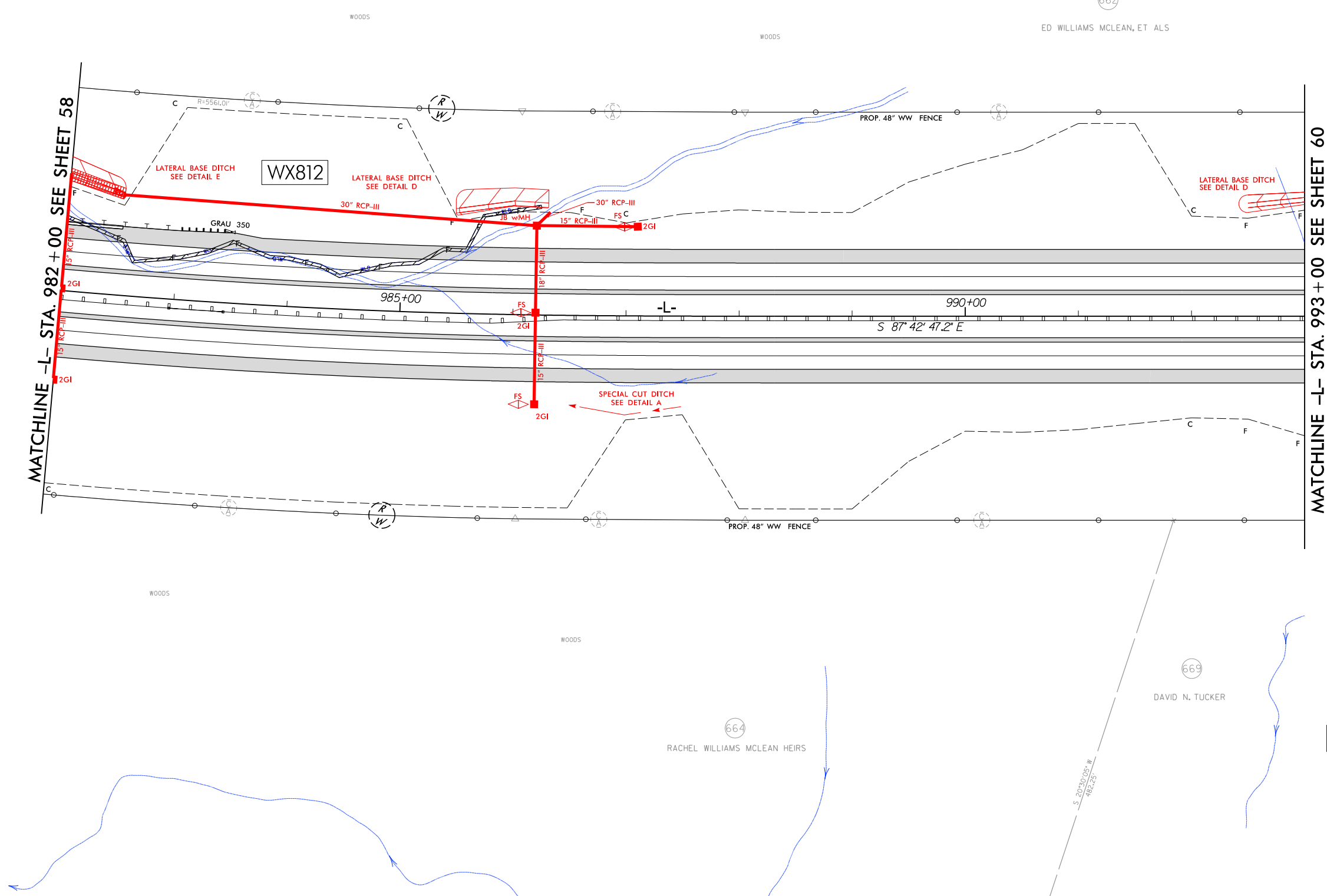

MATCHLINE -L- STA. 993+00 SEE SHEET 60

MATCHLINE -L- STA. 982+00 SEE SHEET 58

FOR -L- PROFILE SEE SHT. 151

**PLANS PREPARED BY :**

**MULKEY**  
ENGINEERS & CONSULTANTS

PO BOX 33127  
RALEIGH, N.C. 27636  
(919) 851-1912  
(919) 851-1918 (FAX)  
WWW.MULKEYINC.COM

FOR  
THE NORTH CAROLINA  
TURNPIKE AUTHORITY

R:\Hyd\paulics\Permt Environmental\VR3329\_R2559\_hyd\_perm\_PSH\_059.dgn